

PUMP PARTS FOR SS

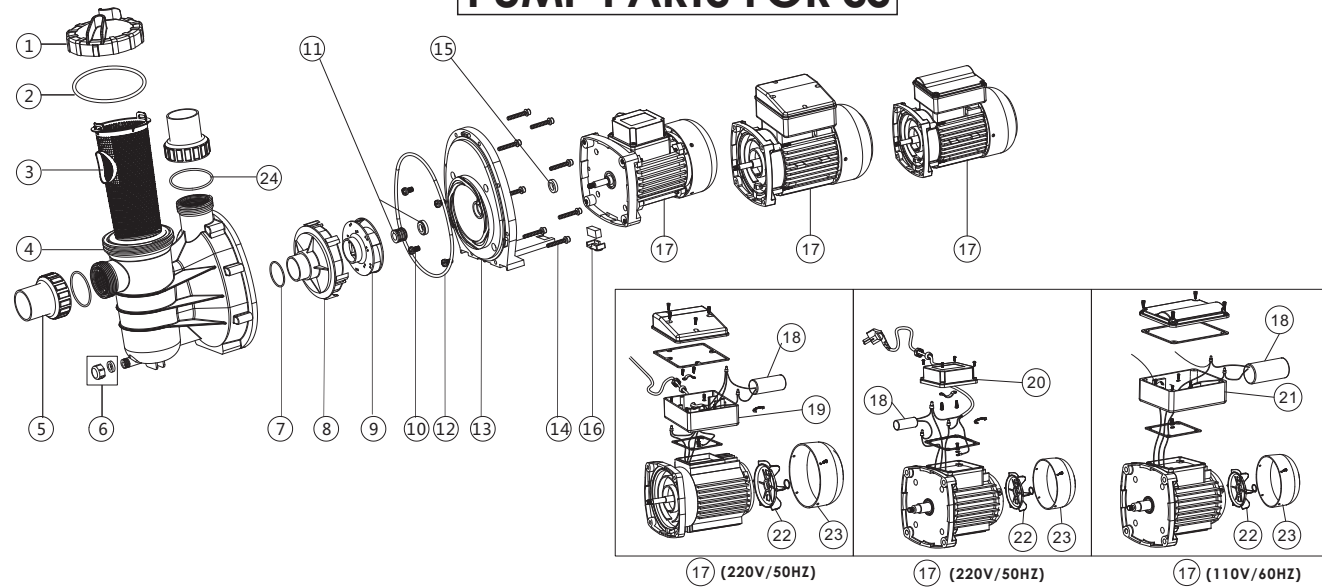

Key No.	Part No.	Description	Qty	Key No.	Part No.	Description	Qty
1	01201031	Transparent Lid	1	17	89022201	Motor SD/SQ/SS/ST020(220V/60HZ)	1
2	02010247	O-Ring for Lid	1	17	89022202	Motor SD/SQ/SS/ST033(220V/60HZ)	1
3	01112051	Basket for SS Pump	1	17	89022203	Motor SD/SQ/SS/ST050(220V/60HZ)	1
4	01021064	SS Pump Pre-Filter	1	17	89022204	Motor SD/SQ/SS/ST075(220V/60HZ)	1
5*	89280105	1.5" Union (Black/ White Colour)	2	17	89022205	Motor SD/SQ/SS/ST100(220V/60HZ)	1
6	89022402	Drain Plug With O'Ring	1	17	89022206	Motor SD/SQ/SS/ST120(220V/60HZ)	1
7	02011004	O-Ring for Diffuser	1	17	89022305	Motor SD/SQ/SS/ST020(110V/60HZ)	1
8	01111014	Diffuser	1	17	89022306	Motor SD/SQ/SS/ST033(110V/60HZ)	1
9	01311014	Impeller SS120(220V/50HZ)	1	17	89022301	Motor SD/SQ/SS/ST050(110V/60HZ)	1
9	01311015	Impeller SD020/SD50/SQ20/SQ50/SS20/SS50/ST20/ST50	1	17	89022302	Motor SD/SQ/SS/ST075(110V/60HZ)	1
9	01311016	Impeller SD33/SD75/SQ33/SQ75/SS33/SS75/ST33/ST75	1	17	89022303	Motor SD/SQ/SS/ST100(110V/60HZ)	1
9	01311017	Impeller SD050/SD100/SQ050/SQ100/SS050/SS100/ST050	1	17	89022304	Motor SD/SQ/SS/ST120(110V/60HZ)	1
9	01311018	Impeller SD075/SD120/SQ075/SQ120/SS075/SS120/ST075	1	18	04016028	Capacitor for SS/SD/SQ/ST050 Pump 110V	1
9	01311019	Impeller SD100/SQ100/SS100/ST100(220V/50HZ)	1	18	04016019	Capacitor for SC050 & SS/SD/SQ/ST075 Pump 110V	1
9	01311023	Impeller SD020/SQ020/SS020/ST020(220V,110V/60HZ)	1	18	04016021	Capacitor for SC075 & SS/SD/SQ/ST100-124 Pump 110V	1
9	01311024	Impeller SD033/SQ033/SS033/ST033(220V,110V/60HZ)	1	18	04016009	Capacitor for SS/SD/SQ/SP/ST050 Pump	1
10	89022403	M8 x 16 Screw with Washer	4	18	04016010	Capacitor for SS/SD/SQ/SP/ST075 & SC050 Pump	1
11	04015033	1/2" Mechanical Seal	1	18	04016012	Capacitor for SS/SD/SQ/SP/ST100-120	1
12	02011090	O-Ring for Flange	1	18	04016032	Capacitor for SS/SD/SQ/ST020 Pump 110V	1
13	01021065	SS Pump Flange	1	18	04016033	Capacitor for SS/SD/SQ/ST033 Pump 110V	1
14	03011035	M6 x 30 Screw	8	18	04016030	Capacitor for SS/SD/SQ/ST020 AMU020P/TP (50/60HZ)	1
15	02011156	Motor Slinger	1	18	04016031	Capacitor for SS/SD/SQ/ST033 Pump	1
16	89022404	Motor Support	1	19	89022112	Cable Box for SD,SQ,SP,ST050-120 Pump	1
17	89022109	Motor SD020/SQ020/SS020/ST020(220V/50HZ)	1	20	89022111	Cable Box for SQ/ST/SD020-033, SS020-SS030 Pump	1
17	89022110	Motor SD033 (220V/50Hz)	1	21	89021505	Cable Box for SA/ ST/ SD 110V	1
17	89022105	Motor SD050/SQ050/SS050/ST050(220V/50HZ)	1	22	01031027	Cooling Fan for SS/SD/SQ/ST050-SS/SD/SQ/ST120 Pump	1
17	89022106	Motor SD075/SQ075/SS075/ST075(220V/50HZ)	1	22	01031026	Cooling Fan for SS/SD/SQ/ST020-SS/SD/SQ/ST030 Pump	1
17	89022107	Motor SD100/SQ100/SS100/ST100(220V/50HZ)	1	23	01031011	Fan Cover for SS/SD/SQ/ST020-SS/SD/SQ/ST030 Pump	1
17	89022108	Motor SD120/SQ120/SS120/ST120(220V/50HZ)	1	23	01031010	Fan Cover for SQ/SP/SS/SD/ST050-SQ/SP/SS/SD/ST120	1
				24	02011104	O-Ring for 1.5" Union	2

Notes: 5* 89280105B is 1.5" Union in Black Colour
5* 89280105W is 1.5" Union in White Colour

**SS Pool & Spa Pump
Installation & Operating Instructions**

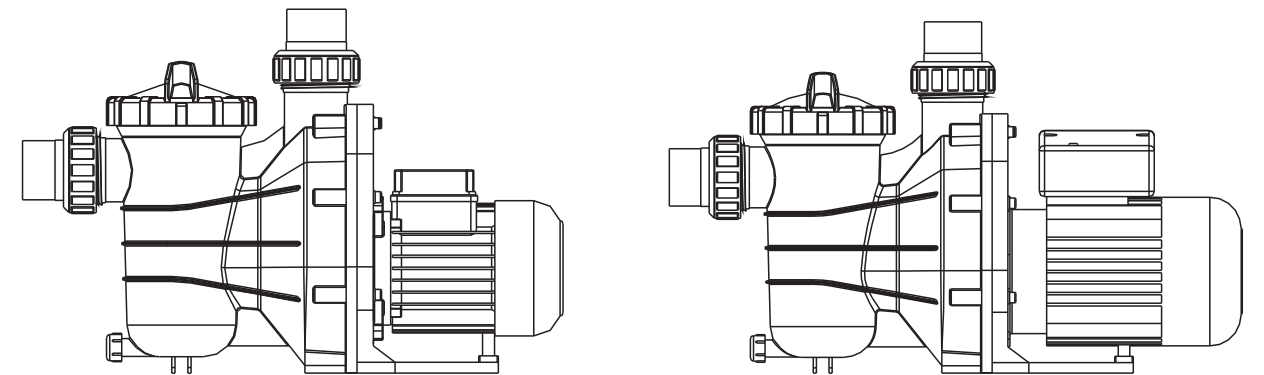

INSTALLATION

Only qualified, licensed personnel should install pump and wiring.

IMPORTANT ELECTRICAL

Electrical Contractors Please Note: EMAUX pumps must be wired to the main power supply through an approved and correctly rated contactor.

Pump Mount Must:

- ❖ Be solid Level Rigid Vibration Free.
- ❖ Allow use of short, direct suction pipe. (To reduce friction losses & don't install the pump at more than 3M geometrical height from water level)
- ❖ Allow for gate valves in suction and discharge piping.
- ❖ Have adequate floor drainage to prevent flooding.
- ❖ Be protected from excess moisture.
- ❖ All adequate access for servicing pump and piping.

NOTICE:

Pump suction and discharge connections have moulded in thread stops, **DO NOT** try to screw pipe in beyond these stops.

OPERATION

▲ **NEVER** run pump dry! Running pump dry may damage seals, causing leakage and flooding! Fill pump with water before starting motor.

▲ Before removing lid:
STOP PUMP before proceeding.
CLOSE GATE VALVES in suction and discharge pipes.
RELEASE ALL PRESSURE from pump and piping system.
NEVER tighten or loosen screws while pump is operation.

▲ Do not block pump suction! To do so with body may cause severe or fatal injury. Children using pool must **ALWAYS** have close adult supervision!

Priming Pump:

- ❖ Release all air from filter and piping system: see filter owner manual.
- ❖ In a flooded suction system (water source higher than pump), pump will prime itself when suction and discharge valves are opened.
- ❖ If pump is not in a flooded suction system, unscrew and remove trap cover; fill trap and pump with water.
- ❖ Clean and inspect Ring; re-install on trap cover.
- ❖ Replace trap cover on trap; turn clockwise to tighten cover.

NOTICE: Tighten trap cover by hand only.

Pump should prime now. Priming time will depend on vertical length of suction lift and horizontal length of suction piping.

ROUTINE MAINTENANCE

The only routine maintenance needed is inspection/cleaning of trap basket. Debris or trash that collects in basket, will choke off water flow through the pump. Follow instructions below to clean trap:

- 1) Stop pump, close gate valve in suction and discharge, and release all pressure from system before proceeding.
- 2) Unscrew trap lid (turn counterclockwise).
- 3) Remove strainer basket and clean. Be sure all holes in basket are clear, flush basket with water and replace in trap with large opening at pipe connection port (between ribs provided). If basket is replaced backwards cover will not fit on trap body.
- 4) Clean and inspect lid Ring; reinstall on trap cover.
- 5) Clean Ring groove on trap body and Replace lid. To help keep lid from sticking, tighten hand tight only.
- 6) Prime pump (see priming instructions above)



SERVICE & REPAIR PARTS

Refer all service to your local agent or dealer as his knowledge of your equipment makes him the best qualified source of information. Order all repair parts through your dealer. Give the following information when ordering repair parts:

- 1) Unit nameplate data or serial number on label.
- 2) Description of part.

TROUBLE SHOOTING

MOTOR DOES NOT START

- 1) Disconnect switch or circuit breaker in off position
- 2) Fuses blown or thermal overload open
- 3) Locked motor shaft
- 4) Motor windings burned out
- 5) Defective starting switch inside single phase motor
- 6) Disconnected or defective wiring
- 7) Low voltage

PUMP DOES NOT REACH FULL SPEED

- 1) Low voltage
- 2) Pump connected for wrong voltage

MOTOR OVERHEATS (protector trips)

- 1) Low voltage
- 2) Motor windings connected for wrong voltage on dual voltage model
- 3) Inadequate ventilation

PUMP DELIVERS NO WATER

- 1) Pump is not primed
- 2) Closed valve in suction or discharge line
- 3) Leakage or air into suction system
- 4) Impeller clogged

LEAKAGE OF WATER AT SHAFT

- 1) Shaft seal requires replacement

LOW PUMP CAPACITY

- 1) Valve in suction or discharge line partly closed
- 2) Suction or discharge line partly plugged
- 3) Suction or discharge line too small
- 4) Plugged basket in skimmer or hair and lint strainer
- 5) Dirty filter
- 6) Impeller clogged

HIGH PUMP PRESSURE

- 1) Discharge valve or inlet fittings closed too much
- 2) Return lines too small
- 3) Dirty filters

NOISY PUMP AND MOTOR

- 1) Plugged basket in skimmer or hair in lint strainer
- 2) Worn motor bearings
- 3) Valve in suction line partly closed
- 4) Suction line partly plugged
- 5) Vacuum hose plugged or too small
- 6) Pump not supported properly

AIR BUBBLES AT INLET FITTINGS

- 1) Leakage of air into suction line at connections or valve stem
- 2) Cover gasket of hair and lint strainer needs cleaning
- 3) Low water level in pool

NOTE: If the recommendations in the trouble shooting portion of this manual do not solve your particular problem(s), please contact your local dealer for service.